

The EW model knife gate valve is a lug type valve designed according to AWWA C520-14 for municipal and general industrial service applications. The design of the body and seat also assures non-clogging shut off on suspended solids in industries such as Pulp & Paper, Power Plants, Chemical Plants, Food & Beverage, etc

Product description:

- Uni-directional lug type knife gate valve
- Size range of DN50-900 (larger sizes upon request).
See Dimension Charts for pressure rating
- Non rising stem as standard. Rising stem also available
- Standard flange connection: ANSI B16.5 / ASME B16.47 and DIN PN10 (EN 1092-2)
Others available upon request
- Manual (handwheel, chainwheel, lever and bevel gear), pneumatic (single and double-acting), electric and hydraulic actuation options available

Features:

- Lug type monoblock ductile iron body with internal cast-in gate wedges and guides
- Port design as per AWWA C520-14 standards
- Stainless steel gate polished both sides to avoid jamming and seat damage
- Standard EPDM resilient seat. Metal-to-metal seat, as well as high performance rings and deflection cones available
- Long life PTFE impregnated synthetic fibre plus EPDM o-ring packing with easy access and adjustable gland follower. Wide range of packing materials available
- RAL-5015 blue epoxy-coating on all cast iron/carbon steel components
- Automated valves provided with gate guards in accordance with EU Safety Standards
- Other options: bonnets, V-ports, flush ports, special materials, fabricated valves, etc.
- Actuation accessories: limit & proximity switches, mechanical stops, positioners, solenoid valves, manual overrides, locking devices, fail safe systems, stem extensions and floor stands

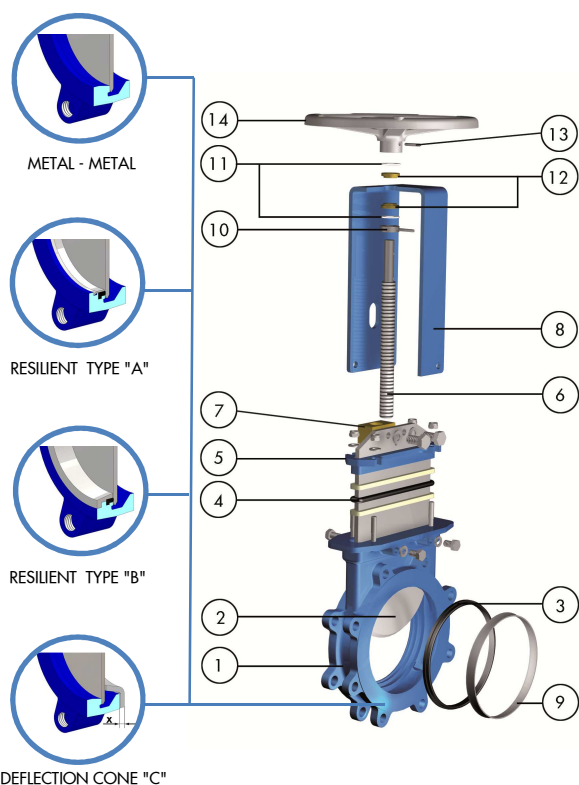
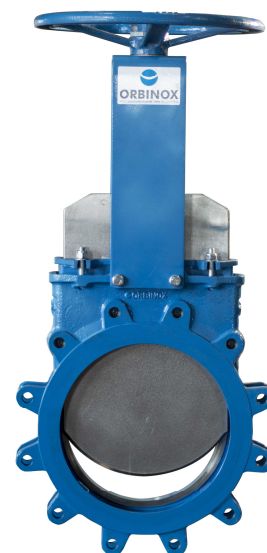

STANDARD PARTS LIST

Part	Ductile Iron:
1	Body GJS 400 (GGG40)
2	Gate AISI 304
3	Seat Metal/Metal, EPDM
4	Packing PTFE impreg. synth. fibre and EPDM o-ring
5	Gland Follower CF8 DN 50mm/2" to DN 300mm/12" or GJS400 (GGG40) DN 350mm/14" to DN 900mm/36"
6	Stem Stainless Steel
7	Stem Nut Brass
8	Yoke Epoxy-coated carbon steel
9	Seat Retainer Ring AISI 304
10	Axial Fixing Bush AISI 304 (1.4301)
11	Friction Washer PET + solid lubricant
12	Guide Bush Bronze
13	Spring Pin AISI 420 (1.4021) (ISO 8752)
14	Handwheel DN≤310: Aluminium (AlSi12); DN≥410 GJS400

DIMENSIONS (mm) Handwheel Non Rising Stem

DN	Pressure	N	A	B	C	D	E	F	ØG	H	Weight (kg.)
50	10 bar	50	48	142	100	98	136	63	225	297	8
80	10 bar	80	51	160	100	119	162	63	225	344	11
100	10 bar	97	51	190	100	139	187	63	225	389	14
125	10 bar	117	57	204	100	150	223	63	225	436	17
150	10 bar	140	57	230	100	165	237	63	225	465	20
200	10 bar	184	70	296	122	203	309	73	310	585	34
250	10 bar	230	70	357	122	233	345	73	310	651	48
300	10 bar	275	76	407	122	273	390	73	410	736	67
350	10 bar	305	76	461	193	312	433	98	410	843	100
400	10 bar	351,6	89	536	193	347	478	98	410	923	130
450	10 bar	390	89	593	197	415	552	98	550	1065	165
500	10 bar	435	114	622	197	450	611	98	550	1159	210
600	10 bar	522	114	700	197	501	697	98	550	1296	300

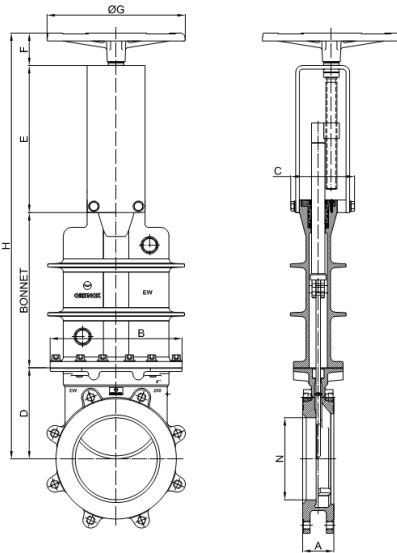
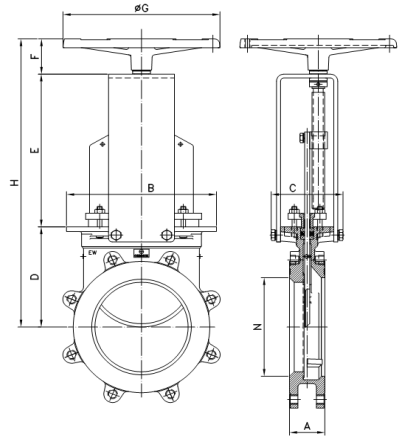

DIMENSIONS (mm) Non Rising Stem with Bonnet

DN	Pressure	N	A	B	C	D	Bonnet	E	F	ØG	H
50	10 bar	50	48	142	124	105	184	196	62,5	225	548
80	10 bar	80	51	160	124	119	218	218	62,5	225	618
100	10 bar	97	51	190	124	142	243	242	62,5	225	690
125	10 bar	117	57	204	124	153	270	276	62,5	225	758
150	10 bar	140	57	230	124	165	297	297	62,5	225	822
200	10 bar	184	70	296	144	203	377	345	72,5	310	997
250	10 bar	230	70	357	144	240	398	388	72,5	310	1099
300	10 bar	275	76	407	144	280	472	432	72,5	410	1257
350	10 bar	305	76	461	205	315	485	508	106	410	1414
400	10 bar	351,6	89	536	205	350	498	585	106	410	1539
450	10 bar	390	89	593	285	415	650	645	110	550	1820
500	10 bar	435	114	622	301	450	715	705	110	550	1980
600	10 bar	522	114	700	301	504	780	785	110	550	2179

DIMENSIONS (mm) Electric Actuator Rising Stem

DN	Pressure	N	A	B	C	D	E	F	ØG	H	I	J	L	M	Stem Ø X pitch	Torque (Nm)
50	10 bar	50	48	124	100	98	136	377	160	454	265	249	62	238	20x4	10
80	10 bar	80	51	149	100	119	162	424	160	501	265	249	62	238	20x4	10
100	10 bar	97	51	169	100	139	187	469	160	546	265	249	62	238	20x4	10
125	10 bar	117	57	169	100	150	223	516	160	593	265	249	62	238	20x4	15
150	10 bar	140	57	197	100	165	237	545	160	1122	265	249	62	238	20x4	20
200	10 bar	184	70	247	122	203	309	667	160	1255	265	249	62	238	24x5	30
250	10 bar	230	70	298	122	233	345	733	160	1321	265	249	62	238	24x5	45
300	10 bar	275	76	349	122	273	390	793	200	1381	283	254	65	248	24x5	70
350	10 bar	305	76	391	193	312	433	875	200	1463	283	254	65	248	36x6	110
400	10 bar	351,6	89	439	193	347	478	955	315	1543	389	336	91	286	36x6	160
450	10 bar	390	89	483	270	415	552	1142	315	1870	389	336	91	286	36x6	190
500	10 bar	435	114	542	270	450	611	1222	400	1950	389	339	91	286	36x6	270
600	10 bar	522	114	637	270	501	697	1444	400	2172	389	339	91	286	40x7	450
700	7 bar	620	114	840	320	576	820	1631	500	2614	430	365	114	303	50x8	500
750	7 bar	670	117	842	320	624	883	1779	500	2832	430	365	117	303	50x8	550
800	7 bar	720	117	933	320	673	922	1867	500	2920	430	365	117	303	50x8	600
900	7 bar	810	117	970	320	779	1046	2035	500	3080	430	365	117	303	60x9	850

